

NEXT X TYPE

49 – 173 kW

Air conditioners for IT Cooling for chilled water feeding.
Operation with ΔT 10°C



 EC FAN

 HIGH EFFICIENCY

 HI-TEMPERATURE

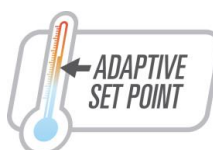

ADAPTIVE
SET POINT



Active
Redundancy

The picture of the unit is indicative and may vary depending on the model

- **pPUE<1,07**
- PERIMETER INSTALLATION
- OPERATION WITH HIGH CHILLED WATER TEMPERATURE FOR THE HIGHEST ENERGY EFFICIENCY
- VARIABLE AIR AND WATER FLOW
- AIR DELIVERY FROM THE BOTTOM (UNDER)
- "X" TYPE HEAT EXCHANGERS
- PLUG FANS WITH EC ELECTRIC MOTORS

Technical Bulletin: T_NEXTXTYPE_0218_GB

NEXT X TYPE

INDEX

MEHITS CERTIFICATIONS.....	3
THE "X" REVOLUTION IN THE PRECISION AIR CONDITIONING.....	4
THE X TYPE SYSTEM.....	7
GENERAL CHARACTERISTICS	9
INSTALLATION.....	10
PRODUCT FEATURES AND BENEFITS	10
MODEL IDENTIFICATION	10
STORING TEMPERATURE.....	10
WORKING LIMITS	11
MAIN COMPONENTS.....	12
OPTIONAL ACCESSORIES	14
TECHNICAL DATA – NEXT X TYPE – EC FANS	15
HYDRAULIC / AERAULIC DIAGRAM.....	16
2-WAY VALVE FOR WATER FLOW CONTROL.....	17
ACOUSTIC DATA	18
ELECTRICAL DATA.....	18
MICROPROCESSOR CONTROL SYSTEM.....	19
NEXT X TYPE - INSTALLATION DIAGRAMS	21
NEXT X TYPE – RAISED FLOOR HEIGHT	22
OPTIONAL ACCESSORIES – CHARACTERISED CONTROL VALVE WITH SENSOR-OPERATED FLOW CONTROL	23
OPTIONAL ACCESSORIES – DOUBLE POWER SUPPLY WITH AUTOMATIC TRANSFER SWITCH	24
OPTIONAL ACCESSORIES - FLOOR STAND	25
OPTIONAL ACCESSORIES - SANDWICH PANELS	27
OPTIONAL ACCESSORIES – M5 EFFICIENCY AIR FILTERS.....	28
OPTIONAL ACCESSORIES – M6 EFFICIENCY AIR FILTERS.....	28
OPTIONAL ACCESSORIES – F7 EFFICIENCY AIR FILTERS.....	28
OPTIONAL ACCESSORIES – NON RETURN MOTORIZED DAMPER.....	29
OPTIONAL ACCESSORIES – COOLNET.....	30
OPTIONAL ACCESSORIES – ADAPTIVE SET-POINT	30
OPTIONAL ACCESSORIES – KIPLINK – KEYBOARD IN YOUR POCKET	30
OPTIONAL ACCESSORIES – RC CLOUD PLATFORM: WEB SERVICES BASED ON CLOUD TECHNOLOGY FOR REMOTE MONITORING AND MANAGEMENT OF AIR CONDITIONING PLANTS.....	31
MACHINE DRAWINGS	32

MEHITS CERTIFICATIONS

SYSTEM CERTIFICATIONS



ISO 9001 CERTIFICATION – MEHITS S.p.A.
Quality Management System



ISO 14001 CERTIFICATION – MEHITS S.p.A.
Environmental Management System



BS OHSAS 18001 CERTIFICATION – MEHITS S.p.A.
Occupational Health and Safety Management System

PRODUCT CERTIFICATIONS BY COUNTRY



CE MARKING

MEHITS units are in compliance with the European Directives in force.



CCC – CQC CERTIFICATION
(People's Republic of China)



EAC CERTIFICATION
(Russian Federation, Belarus, Kazakhstan)



THE “X” REVOLUTION IN THE PRECISION AIR CONDITIONING



The first air conditioner for computer rooms



MRE/A
The first air cooled chiller with built-in free-cooling system



SILVERBULLET
The prototype of air cooled chiller equipped with oil-free centrifugal compressor with magnetic levitation system

4th July, 1963 RC was established with the mission of providing innovative and high quality air conditioning systems.

The commitment to research and use the latest technology available in the market has led the company to produce one of the first air conditioners for computer rooms for a leading Italian bank; to conceive the first chillers with free-cooling system built, the series MRE / A; to realize the first capillary pipes in plastic material for the refrigerant gas; to develop, jointly with the manufacturer, the two-stage centrifugal compressor with magnetic levitation of air-cooled chillers with the prototype Silverbullet. In addition, the company has always been organized internally for the study and development of software applications for the management of its units and the plant where units are installed.

This philosophy, combined with continuous efforts in the search for energy saving, have led the company to design and develop a new concept of Precision Air Conditioning



NEXT X TYPE: an innovative air conditioner with a revolutionary idea, structure and application, with the aim to reduce energy consumption, dramatically reduce maintenance costs, provide high reliability and continuous operation and to meet the requirements of the Data Center of last generation that provide for stringent operating conditions to obtain extremely high values in terms of performance and efficiency.

Here's what Google publishes on its website, as regards the efficiency of its Data Centers. (<http://www.google.com/about/datacenters/efficiency/index.html>)

Efficiency

When you use Google products, the servers in our data centers do the work for you—around the clock and around the world. Our servers support many products at a time. That's "the cloud." By keeping our servers busy, we can do more with less—more searches, more Gmail, and more YouTube videos with fewer servers and less energy.

Measuring and improving our energy use

We're focused on reducing our energy use while serving the explosive growth of the Internet. We take detailed measurements to continually push toward doing more with less—serving more users while wasting less energy.

Building custom, highly-efficient servers

Google's servers are high-performance computers that run all the time. They're the core of our data centers, and we've designed them to use as little energy as possible.

We rise the thermostat to 26,67°C (80°F)

One of the simplest ways to save energy in a data center is to raise the temperature. It's a myth that data centers need to be kept chilly.



Logos, Trade Marks and Company Name, are property of the respective Owners



PUE

The main parameters for the evaluation of the Data Center can be summarized in:

PUE = Power usage effectiveness
 TIER = reliability classification

PUE (power usage effectiveness): Effectiveness in energy use in the Data Center

The energy efficiency of a Data Center is defined by the PUE, an index that compares the total installed power in the infrastructure (IT equipments + Cooling + Back-up + others) with one used only by IT equipments for data processing. To have an efficient Data Center, the result should be close to 1.

Sample calculation for a Data Center with IT equipments with a power consumption of 500 kW:

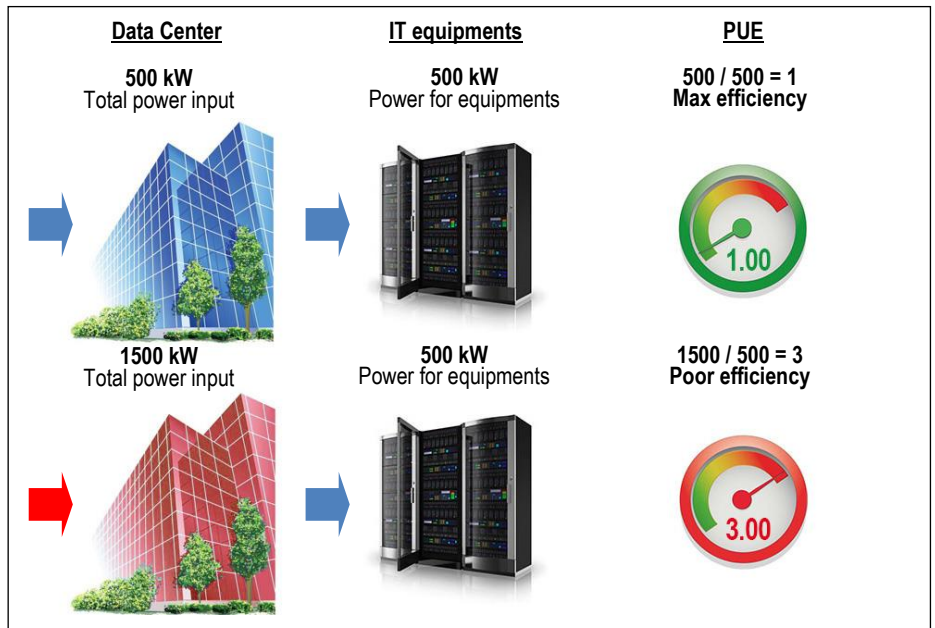

The chart below shows the PUE average values of the major Data Center in the world from 2011 to 2014. The average was calculated on the values provided by the respective Data Center (source Uptime Institute, Symposium in Santa Clara – California).

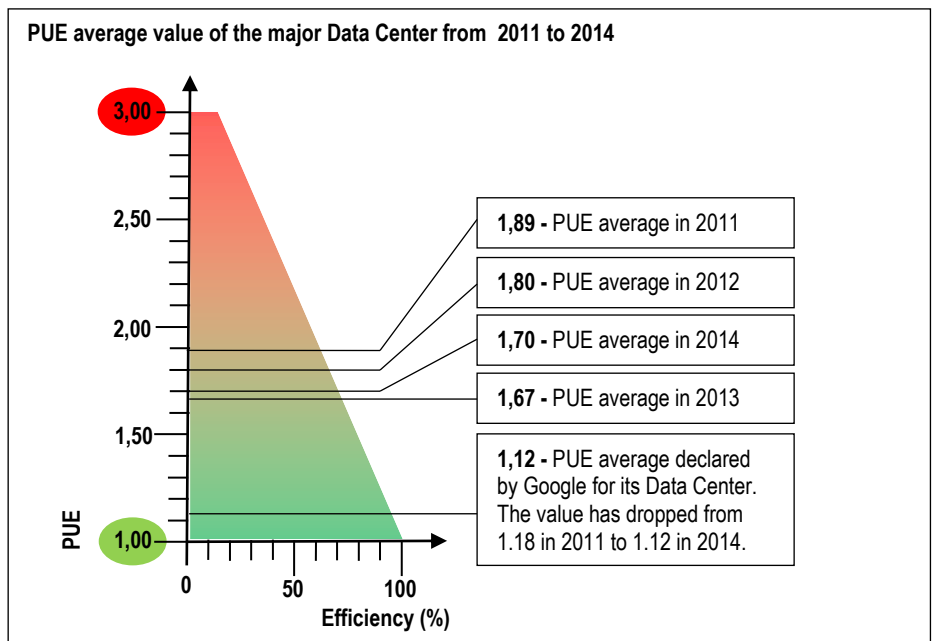

Uptime Institute is a consortium of companies that engage in education, publications, consulting, certifications, conferences and seminars for the data center industry.

It is best known for its widely adopted tier certifications of data centers (TIER).



TIER

TIER: Data Center reliability classification

The Uptime Institute has created the **TIER** classification to evaluate the data center infrastructure in terms of performance or guarantee of continued operation (uptime).

The **TIER** classification is recognized worldwide and is divided into four classes.

Classes are progressive; each **TIER** incorporates all levels of the previous one.

TIER I (basic – expected uptime levels of 99,671%)

- Susceptibility interruptions due to planned and unplanned activities;
- Lack of redundancies and with single power supply system and cooling;
- Presence or absence of UPS, generators and floating floor;
- Data center downtime: 28.8 hours/year;
- Total off during preventive maintenance.

TIER II (redundant component – expected uptime levels of 99,749%)

- Less susceptibility to interruptions due to planned and unplanned activities;
- Redundant components with single power supply and cooling;
- Presence of UPS, generators and floating floor;
- Data center downtime: 22 hours/year;
- Total off during maintenance of power and other parts of the infrastructure

TIER III (concurrently maintainable – expected uptime levels of 99,982%)

- Ability to perform scheduled maintenance without interruption, but susceptibility to interruptions due to unplanned activities;
- Redundant components and connections to multiple power and cooling;
- Presence of UPS, generators and floating floor;
- Data center downtime: 1.6 hours/year;
- Do not need to turn off completely during maintenance, switch to other connections for power and infrastructure.

TIER IV (fault tolerant – expected uptime levels of 99,995%)

- Ability to perform scheduled and unscheduled maintenance, without any negative impact on the management of its functions;
- Redundant components and multiple links simultaneously active power and cooling;
- Availability of UPS, generators and floating floor;
- Data center downtime: 0.04 hours/year;
- Do not need to turn off completely during maintenance, switch to other connections for power and infrastructure.

DIAGRAM FOR ARCHITECTURE OF A DATA CENTER TIER IV

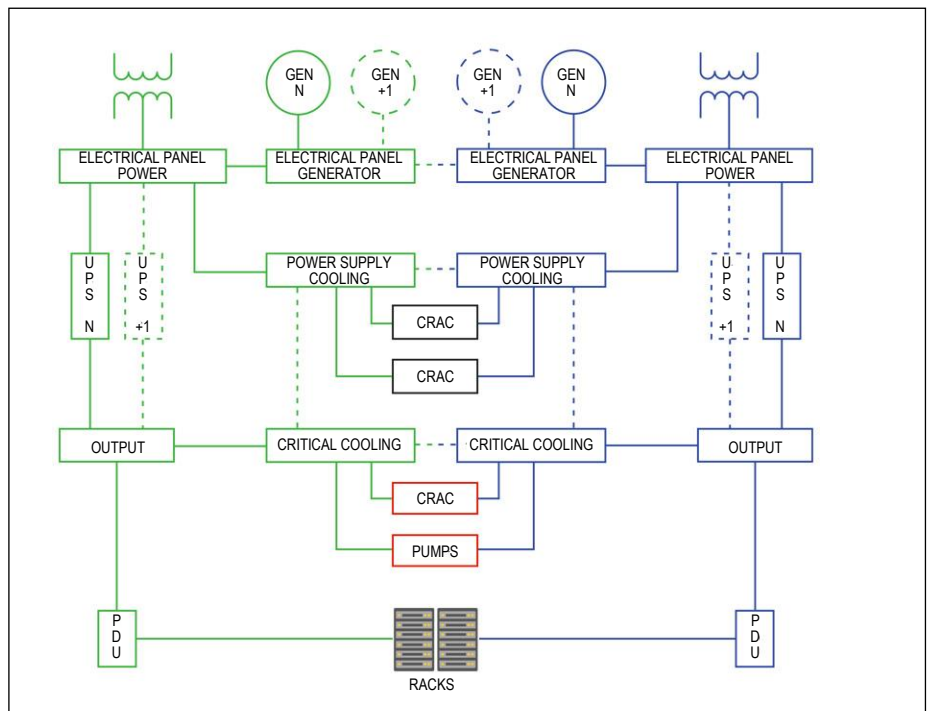

THE X TYPE SYSTEM

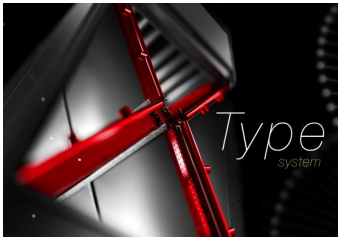

Project **NEXT X TYPE** has been developed and realized according to the new standards of the modern data center and with the objective to maximize the performance of the machine.

The design data for the operating temperatures of the system are:

- Air return temperature: 35°C or higher
- Air delivery temperature: 23°C or higher
- Chilled water inlet temperature: 18°C or higher
- Chilled water outlet temperature: 28°C or higher with minimum Δt 10°C
- SHR ratio: 1
- EER at maximum air flow: 21
- EER at minimum air flow: 80

Around these values we have developed the **NEXT X TYPE** project that has materialized in a revolutionary double-stage cooling heat exchanger and the use of the state of the art in terms of components with high efficiency

The study was not limited to the thermodynamic calculations but was deepened with a CFD analysis.

CFD: Computational Fluid Dynamics is a branch of fluid mechanics that uses numerical methods and algorithms to solve and analyze problems that involve fluid flows.



X Type
General view

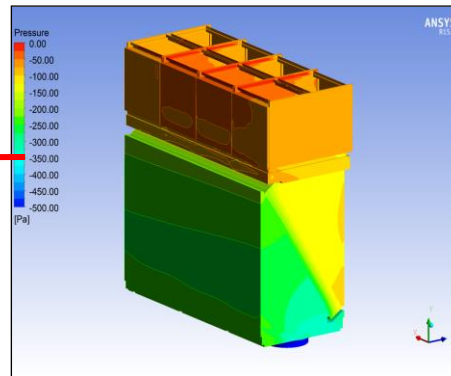

CFD analysis of pressure drop of the prototype NEXT X TYPE

CFD analysis of the pressure drop of the prototype NEXT X TYPE. "X" coil has lower air side pressure drops when compared with a traditional 8 rows coil.

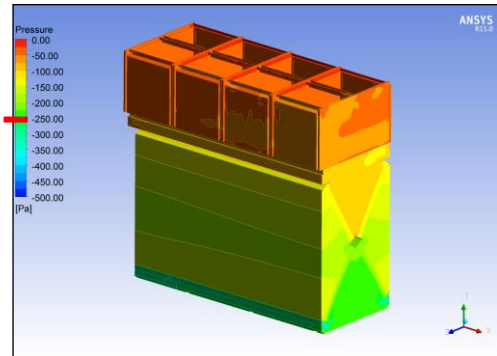

Result from this study / analysis was the construction of a prototype **NEXT X TYPE**, with a cooling capacity of 140 kW, characterized by an innovative lay-out to ensure the highest possible performance:

- Symmetrical heat exchanger with two cooling stages
- Supply fans in axis with the heat exchanger
- No piping in the heat exchanger section
- No valve in the heat exchanger section
- Electric panel on lateral side of the heat exchanger section
- Low turbulence on air side
- Air side pressure drops minimized
- Water side pressure drops minimized due to symmetry of the heat exchanger

FUNCTIONAL DIAGRAM

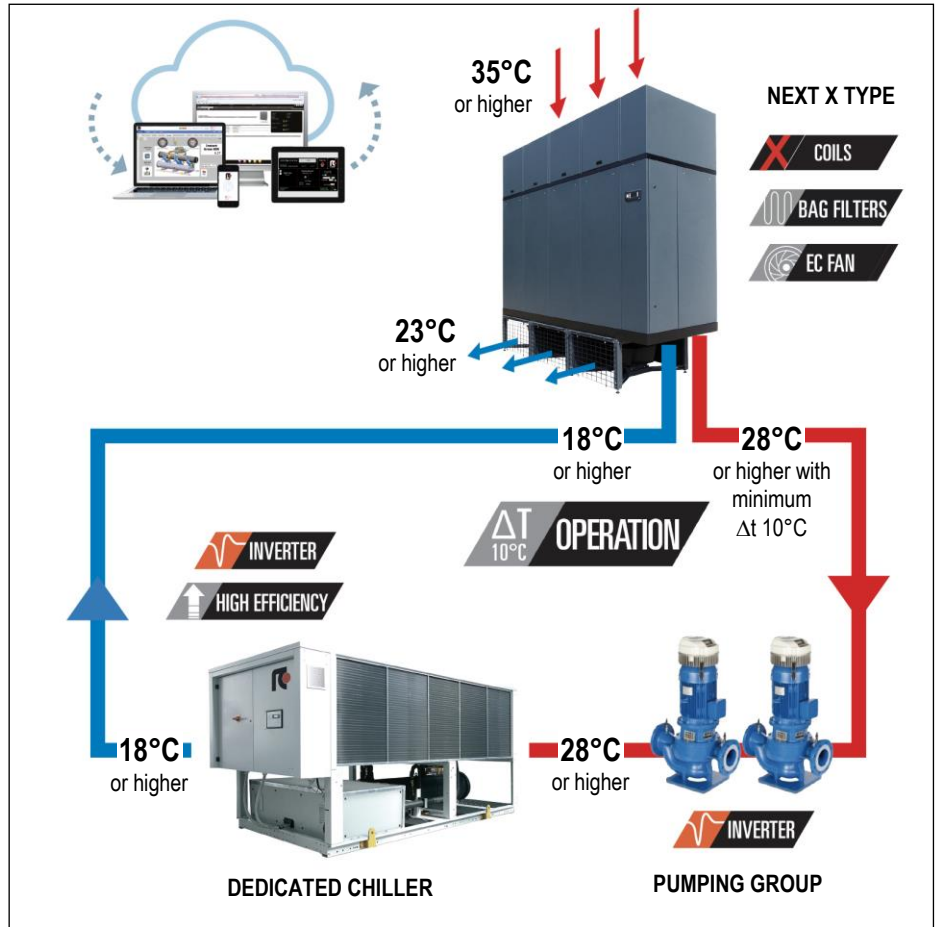

The functional diagram shows the hardware and the operating temperatures of a plant with the system **NEXT X TYPE**.

The chiller

The chiller is provided for operation with refrigerant R410A or HFO1234ze. It is equipped with oil-free centrifugal compressors and can be supplied in standard version or with free-cooling system. The chillers provide dedicated components for the production of chilled water at high temperature (inlet temperature 28°C or higher; outlet temperature 18°C or higher) with minimum ΔT 10°C.

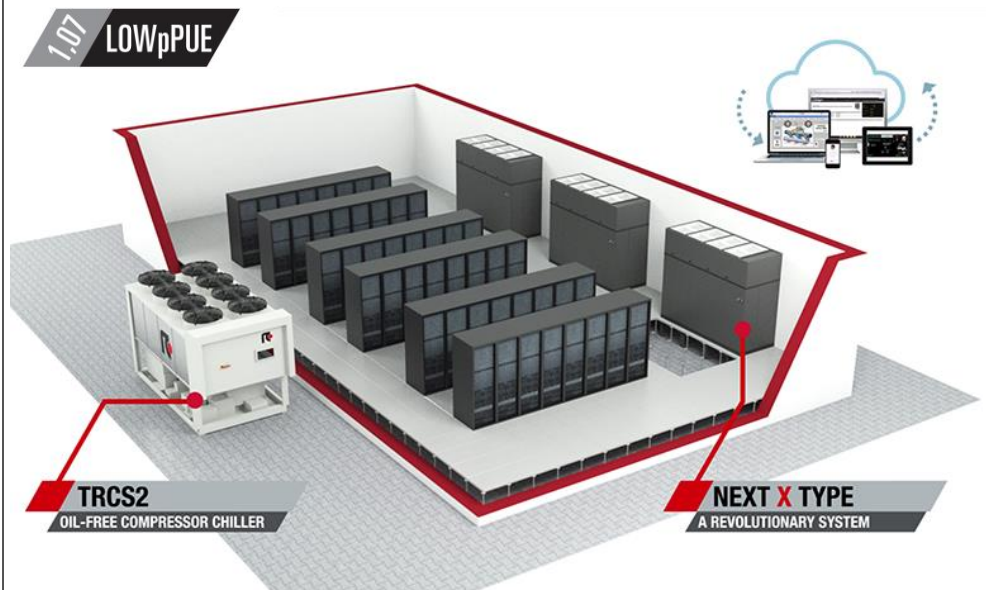

GENERAL CHARACTERISTICS



NEXT X TYPE: Air conditioners for IT Cooling for chilled water feeding with supply fans section for installation in underfloor.

The system meets all the quality requirements in modern data centers as:

- Flexible and modular system integration
- Absolute reliability
- Very low maintenance cost
- Energy monitoring and management integrated in the system
- No water consumption and related treatment

The machines are characterized by the combined system of water flow and air flow variables. This series is offered in 4 models, all available in downflow version with air intake from the top. Cooling capacity: 49 ÷ 173 kW

The machines is provided in separate sections to be assembled during installation.

SUPPLY FAN SECTION

The section is divided into several boxes each containing its own fan with safety net. The boxes are to be installed and assembled on site in the void of the raised floor, creating the foundation on which will be based the air handling section.

AIR HANDLING SECTION

Packaged section that includes the heat exchanger, the electric panel and water flow control valves. The section is longer than the underlying fan section to allow the transit of the hydraulic pipes and electric cables for power and control without impact on the fan section.

FILTERS SECTION

The section is divided into several boxes each containing two bag filters. The boxes have to be installed and assembled on site over the air handling section.

The machines are made for indoor installation.

The constructive solutions and the internal lay-out allow high application flexibility and the frontal access to the main components for the inspection and routine maintenance.

The installation requires electrical and hydraulic connections.

Final assembly on all machines before shipment including running test, reading and monitoring of operating parameters, alarms simulation and visual check.

NEXT X TYPE

INSTALLATION



DOWNFLOW VERSION (Under)

Typical installation is on the perimeter.

The units are placed along the perimeter of the data center. Air suction from the top of the unit and air delivery in the underfloor void.

The air distribution is achieved by special tiles placed in front of the racks row, forming cold aisle for air diffusion. On the rear of the racks is expelled the hot air (hot aisle) then aspirated by the unit.

For an optimal installation is advisable to provide the cold aisle containment.

OPTIONAL

A list of accessories allows the unit to adapt effectively to the real needs of the system, reducing the time and cost of installation.

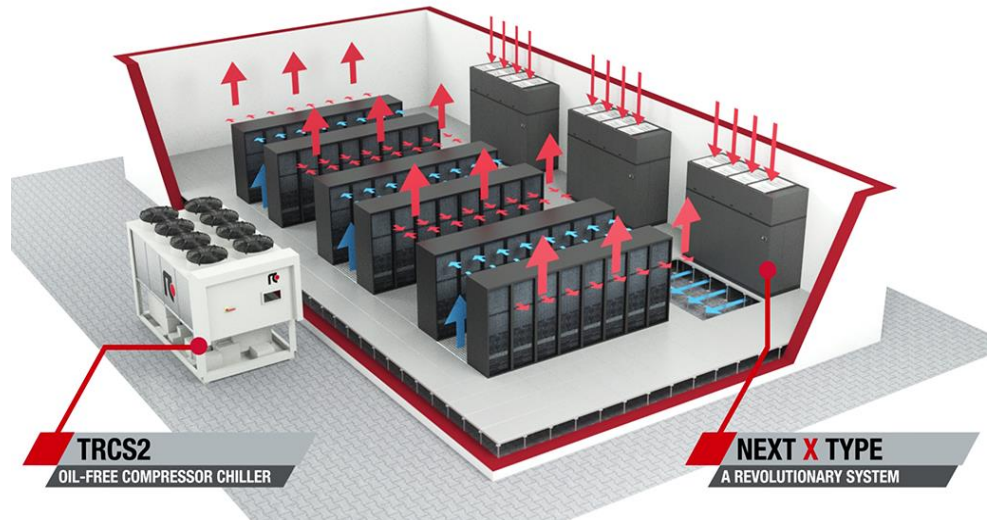

PRODUCT FEATURES AND BENEFITS

NEXT X TYPE represents the state of the art of the air conditioning for data centers with low energy consumption:

- Machine designed according to a CFD analysis (**Computational Fluid Dynamics**)
- SHR ratio = 1;
- Optimization of the air circuit;
- Optimization of the hydraulic circuit;
- New plug fans with EC electric motors and composite impeller of the latest generation, which guarantees a reduction of power consumption;
- New fans electric motor that do not require maintenance;
- Improvement of the control software, developed by MEHITS, with advanced control logic;
- Bag filters of large surface that reduce replacement operations to once a year;
- Panels fully removable to facilitate the operations of extraordinary maintenance;

MODEL IDENTIFICATION

NEXT X TYPE T1 S
NEXT X TYPE **Series identification**
T1 **Cabinet size**
S **Version**

STORING TEMPERATURE

If the machine is not installed on receipt and is stored for a long time, store it in a protected place, at temperatures ranging between -30°C and 50°C in absence of superficial condensation and direct sun light.



NEXT X TYPE

WORKING LIMITS

HYDRAULIC CIRCUIT

10 Bar Maximum working pressure of the hydraulic circuit

POWER SUPPLY

± 10% Maximum tolerance of the supply voltage (V)

WORKING CONDITIONS

The particular NEXT X TYPE project foresees operation conditions of ratio SHR = 1 to maximize the efficiency of the machine.

The variables involved in order to achieve this objective are:

- Machine air flow
- Room air temperature
- Room air humidity
- Chilled water temperature
- Water side pressure drops
- SHR = 1

Deviations, even in small quantities, by the nominal operating conditions

- Air return conditions: 35°C – 30%rH
- Air delivery temperature: 25°C
- Chilled water inlet temperature: 18°C
- Chilled water outlet temperature: 28°C

require a verification of the unit to the new working conditions.

For operating conditions different than the nominal, please contact your local Agent or the MEHITS Sales Department to verify your requirements and provide the solution for your system.

The limit conditions of operation (green area) are still summarized in the diagram below. Important to note the limits of Humidity Ratio within which the system must operate.

The adjacent table shows the maximum permissible values of Humidity Ratio with the temperature of chilled water inlet to the machine.

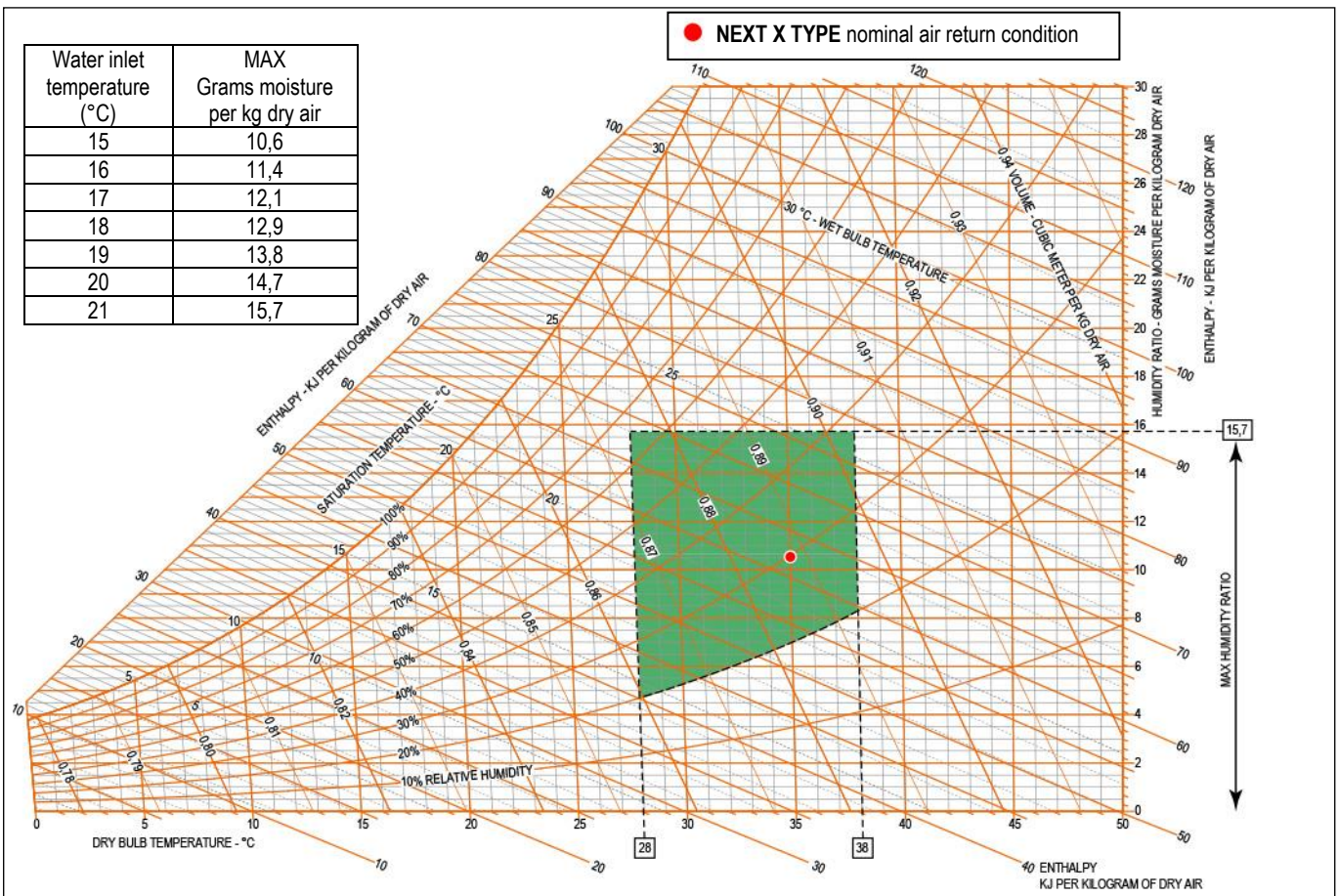

MAIN COMPONENTS



Fans section



Heat exchanger section



Water flow control valve section

FANS SECTION

The section is divided into several boxes each containing its own fan with safety net. The boxes are to be installed and assembled on site in the void of the raised floor, creating the foundation on which will be based the air handling section.

- Frame in galvanized steel sheet with protective surfaces treatment in compliance with UNI ISO 9227/ASTMB117 and ISO 7253, and painted with epoxy powders. Colour RAL 7016 hammered;
- Height adjusting rubber holders.
- Centrifugal fans with backward curved blades with wing profile, single suction and without scroll housings (Plug-fans), directly coupled to external rotor electric motor.
 - Impeller in composite material exempt from rust formation.
 - Brushless type synchronous EC motor with integrated electronic commutated system and continuous variation of the rotation speed. The motor rotation control is obtained with the EC system (Electronic Commutation) that manage the motor according to the signal coming from the microprocessor control.
- Fan guard on air delivery.
- Connecting cables with the unit electrical panel for power and control signals for fan motors.
- Fans control with proportional signal 0-10V.
- Supports for the tiles of the raised floor. The supports are adjustable in height to adapt to the thickness of the tiles.



AIR HANDLING SECTION

Packaged section is that includes the heat exchanger, the electric panel and water flow control valves. The section is longer than the underlying fan section to allow the transit of the hydraulic pipes and electric cables for power and control.

- Base and top frame in extruded aluminium, painted with epoxy powders. Colour RAL 9005;
- Panels in galvanized steel sheet with protective surfaces treatment in compliance with UNI ISO 9227/ASTMB117 and ISO 7253, and painted with epoxy powders. Colour RAL 7016 hammered;
- Panels insulated with polyurethane foam and seals to ensure air tight.
- "X" type heat exchanger coil with 2 cooling stage with copper tubes and high efficiency aluminium fins, specifically developed to provide high heat transfer and lower air side and water side pressure drops.
- Frame in galvanized steel.
- Condensate tray in peralluman with PVC flexible discharge pipe.
- Compartment for hydraulic section on the right side of the unit and containing 2-way motorized valve for water flow regulation with 0÷10 VDC control actuator and emergency manual control.
- Temperature sensors on air intake and air delivery with control, regulation and limitation functions.
- Temperature sensor on chilled water inlet and outlet.
- Hydraulic pipes
- Hydraulic connections on the right side of the unit





Electrical panel section

Compartment for electrical panel on the right side of the unit with panel. Electrical panel in accordance with EN60204-1 norms, suitable for indoor installation, complete with:

- External panel
- Internal panel on which are located the controls and safety devices
- Main switch with door lock safety
- Magnetohermic switches for supply fans. The supply fans equipped with EC electric motor don't require contactors.
- Transformer for auxiliary circuit and microprocessor supply.
- Connecting cables for power and control signals for fan motors.
- Power supply 400/3/50+N.
- Terminals:
- OUTLETS
 - Voltage free deviating contact for General Alarm 1-2.
 - Voltage free contact for supply fans status.
- INLETS
 - External enabling.



Filters section

FILTERS SECTION

The section is divided into several boxes, each containing two bag filters removable from the unit front. The boxes are to be installed and assembled on site over the air handling section.

- Disposable bag filters with G4 efficiency, with cells in synthetic fibre and metallic frame (EN 779-2002).
 - Filters are not regenerable.
 - The high filtering surface ensures a year of operation before replacement.



Microprocessor display

CONTROL SYSTEM

Microprocessor control system with graphic display for control and monitor of operating and alarms status.

The system includes:

- Built-in clock for alarms date and time displaying and storing;
- Built-in memory for the storing of the intervened events (up to 200 events recorded);
- Predisposition for additional connectivity board housing (MBUS RS485/JBUS, MBUS RS232/JBUS for GSM modem, LON, BACnet for Ethernet (SNMP- TCP/IP), BACnet for MS/TP). The electronic cards are optional accessories.
- Main components hour-meter;
- Non-volatile "Flash" memory for data storage in case of power supply faulty;
- Menu with protection password;
- LAN connection (max 10 units).



OPTIONAL ACCESSORIES

The descriptions of these additional components can be found in Chapter OPTIONAL ACCESSORIES.

- Pressure independent 2-way motorized valve with 0-10 VDC control actuator and emergency manual control.
- Double power supply with automatic change-over.
- Unit floor stand with height adjusting rubber holders.
- Double panels in Euroclass A1.
- Disposable bag air filters with M5 efficiency.
- Disposable bag air filters with M6 efficiency.
- Disposable bag air filters with F7 efficiency.
- Non-return air damper driven by electric servomotor installed inside the unit.
- COOLNET: application software to maximize energy saving in Load Sharing.
- ADAPTIVE SET POINT: software that optimizes the operation of liquid chillers connected to the indoor air conditioners by control of the effective room thermal load.
- KIP LINK: Keyboard in your pocket. Allows to operate on the unit with smartphone or tablet.
- RC CLOUD PLATFORM: Web services based on cloud technology for remote monitoring and management.

OTHER ACCESSORIES

- Automatic system for the air pressure control in the under floor void. The system controls the supply fans rotation speed in order to keep constant the air pressure in the under floor via a differential pressure transmitter connected to the microprocessor control.
- Differential pressure switch on the air side for clogged filters alarm signal.
- Under floor water alarm through sensor to be placed on the floor.
- Additional underfloor water sensor kit.
- Main switch with door lock safety on the electrical box external panel.
- Combined Temperature / Humidity sensor on air return.
- Combined Temperature / Humidity sensor for remote installation. The optional is added to the standard sensor on machine air return.
- Microprocessor control accessories:
 - Shared remote terminal.
 - Serial card MBUS RS485/JBUS.
 - Serial card MBUS RS232/JBUS for GSM modem.
 - Serial card LON.
 - Serial card BACnet for Ethernet – SNMP – TCP/IP.
 - Serial card BACnet for MS/TP.
 - Temporary microprocessor power supply. The system guarantees the microprocessor power supply for a few minutes, in case of supply voltage failure.

WARNING

MEHITS reserves the right to accept the matching of the optional installed on the machine.

NEXT X TYPE

TECHNICAL DATA – NEXT X TYPE – EC Fans

MODEL		T1 S	T2 S	T3 S	T4 S
COOLING CAPACITY (1)					
Total	kW	49,3	93,3	133,0	173,0
Sensible	kW	49,3	93,3	133,0	173,0
SHR RATIO (2)					
	kW/kW	1	1	1	1
EER (Energy Efficiency Ratio)					
	kW/kW	40,7	32,0	29,3	27,8
“EC” SUPPLY FANS					
	n.	1	2	3	4
Air flow	m ³ /h	11000	21200	30600	40000
Nominal external static pressure	Pa	20	20	20	20
Max external static pressure	Pa	330	280	270	260
Power input (3)	kW	1,21	2,92	4,54	6,22
“X” TYPE COOLING COIL					
Water flow rate (1)	m ³ /h	4,2	8,1	11,5	15,0
dP coil + valve (1)	kPa	22	44	34	31
Water volume	l	40	63	85	110
AIR FILTERS					
	n.	4	6	8	10
Efficiency		G4	G4	G4	G4
Filtering surface	m ²	11,8	17,6	23,5	29,4
POWER SUPPLY					
	V/Ph/Hz	400/3/50+N	400/3/50+N	400/3/50+N	400/3/50+N
DIMENSIONS					
Length	mm	1620	2260	2900	3540
Width	mm	1100	1100	1100	1100
Height of handling section + filters section (4)	mm	2375	2375	2375	2375
Height of fans section (5)	mm	525	525	525	525
TOTAL NET WEIGHT					
	kg	494	765	1042	1330
Air handling section	kg	357	525	703	892
Filters section	kg	64	94	120	146
Fans section	kg	73	146	219	292
HYDRAULIC CONNECTIONS					
WATER INLET / OUTLET ISO 7/1 - R	Ø	1+1/2"	2"	2"	2+1/2"
Condensate discharge – Rubber pipe	F Ø	1/2"	1/2"	1/2"	1/2"

THE COOLING CAPACITY DOES NOT CONSIDER THE SUPPLY FAN MOTOR THERMAL LOAD

1. Gross value. Characteristics referred to entering air at 35°C - 30%RH; chilled water temperature 18-28°C - 0% glycol. ESP=20Pa.
2. SHR = Sensible cooling capacity / Total cooling capacity
3. Corresponding to the nominal external static pressure
4. Includes air handling section and filters section
5. The fans section is installed in the raised floor void

NEXT X TYPE

HYDRAULIC / AERAULIC DIAGRAM

Below the hydraulic / aeraulic diagram of the standard configuration with no optional and the relative operating temperatures.

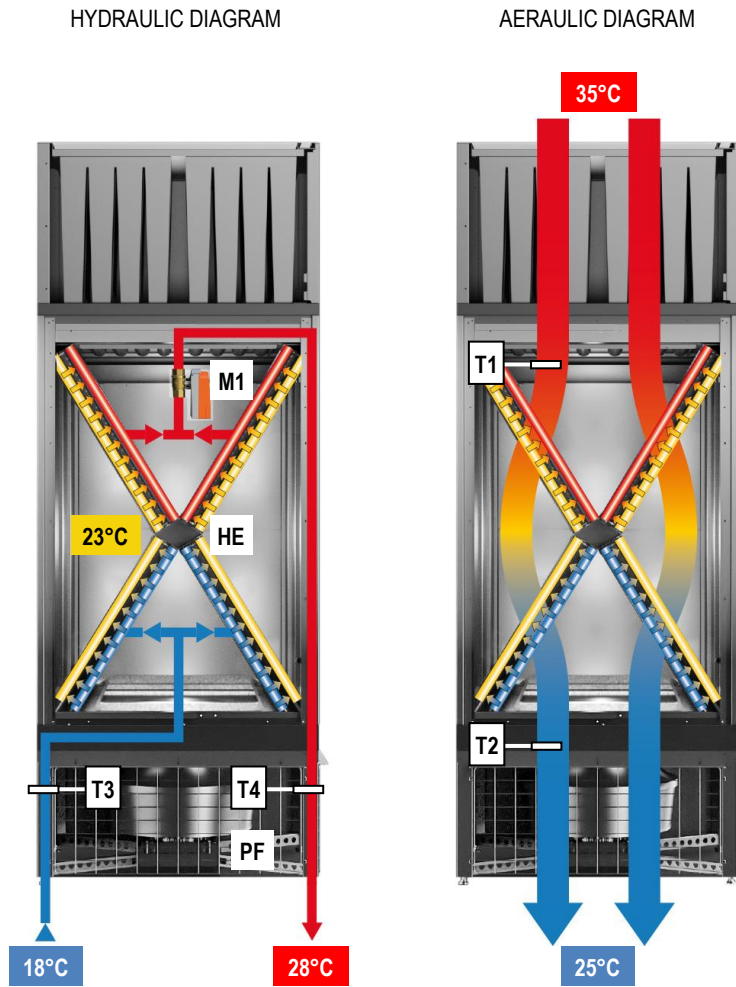

LEGENDA

M1 2-way motorized valve for mail coil
 HE Main coil
 PF Plug Fan.

T1 Air return temperature probe
 T2 Air supply temperature probe
 T3 Chilled water inlet temperature probe
 T4 Chilled water outlet temperature probe

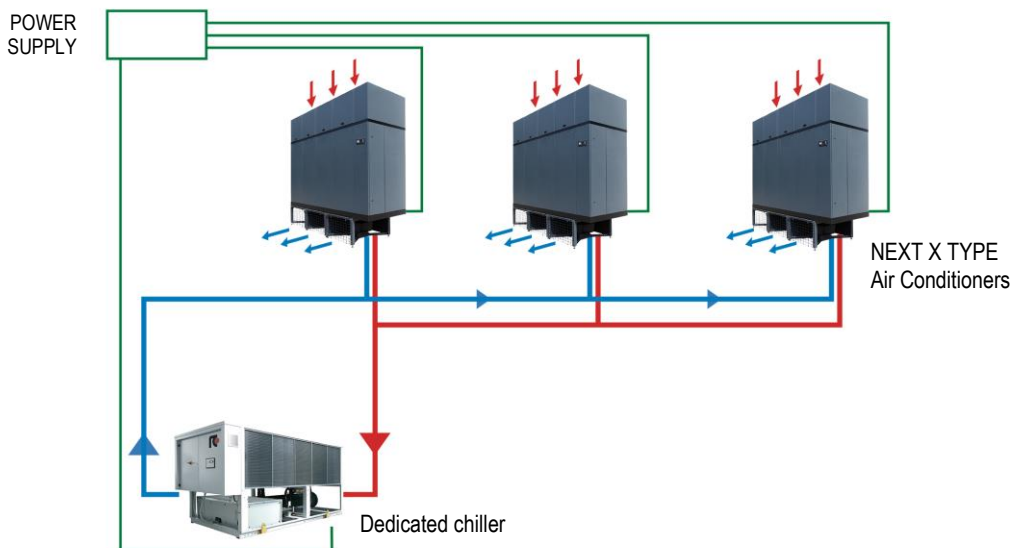

2-WAY VALVE FOR WATER FLOW CONTROL

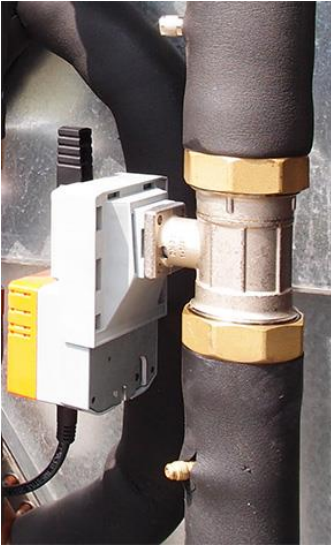

The water flow control in the finned coil is achieved through a **2-way modulating ball valve**.

Distinctive features of these valves are the water flow equal percentage and optimum cooling capacity control ensured by the integrated characterizing disc.

As is known, the variation of cooling capacity expressed by the heat exchanger is not linear to the change in fluid flow rate. In fact, at a flow variation of 20% may correspond a variation of 40% of cooling capacity. The use of valves with equal percentage characteristics allows to solve this concern, as the fluid flow rate does not vary linearly with the opening of the valve.

This type of valve offers the following series of benefits:

- Equal percentage flow control.
- Closing seal with leakage rate in Class A (EN 12266-1)
- No peaks initial flow.
- Excellent stability control thanks to the integrated characterizing disc.
- Closing pressure very high.
- Excellent characteristic in partialisation.
- Stability in control.
- Wide operating pressures which provide an optimal adjustment of the water flow even under extreme conditions.
- Maintenance free.
- Self-cleaning.

The rotative actuator is controlled by a signal 0 ... 10VDC from the microprocessor controller. The actuator is equipped with an emergency button for manual operation and is maintenance-free.

NEXT X TYPE

ACOUSTIC DATA

Acoustic data of the standard machine at full load working conditions.

WARNING:

In a closed room the noise produced by a sound source reaches the listener in two different ways:

- Directly
- Reflected from the surrounding walls, floor, ceiling, from furniture.

With the same sound source, the noise produced in a closed room is greater than that produced outdoors. In fact, the sound pressure level generated by the source, must be added to the one reflected from the room. Also, the shape of the room affects the sound.

Indicatively the noise increase varies from +4 to +6 dB (A).

MODEL		T1 S	T2 S	T3 S	T4 S
On air delivery	dB(A)	74,2	75,7	76,8	77,7
On air intake	dB(A)	63,1	67,2	68,3	69,0
On unit front	dB(A)	55,6	60,0	61,4	62,3

1. Noise pressure level at 1 meter in free field – ISO 3744

UNIT NOISE EMISSION

$L_p A$ = Catalogue value from front side
 $L_p B$ = Catalogue value from air delivery side
 $L_p C$ = Catalogue value from air intake side

The point B does not influence the point A

$$L_p A+C = 10 \log_{10} \left(10^{\frac{L_p A}{10}} + 10^{\frac{L_p C}{10}} \right)$$

ELECTRICAL DATA

NEXT X TYPE

MODEL		T1 S	T2 S	T3 S	T4 S
Power supply		400/3/50+N	400/3/50+N	400/3/50+N	400/3/50+N
Maximum current input	A	4,2	8,3	12,5	16,6



MICROPROCESSOR CONTROL SYSTEM



The microprocessor control system is equipped with 6 keys terminal and back lighted graphic display on which all information in different languages or easily identifiable symbols are displayed. The system disposes of a "flash" memory that preserves the information even in absence of power supply. Part of memory is dedicated to the registration of intervened events - up to 200 events.

KEYBOARD FUNCTIONS

	ALARM	Alarm, Back-red light active – alarm presence, push to have alarm description. If more than one alarm(s), the others can be scrolled by Key UP / DOWN
	PRG	Menu list, scrolled by key UP/DOWN: Unit; Set-point; In/Out; Clock; History; User; Service; Factory. Use the ENTER key to execute the mode.
	ESC	Home. Used to come back to the previous menu level or to the main screen.
	UP DOWN	Used to change the pages and values of sets. When display is in main screen (HOME), pressing one of them (UP/DOWN) will display the synoptic of the main controls.
	ENTER	Moving the cursor on adjustable Program(s) fields, to confirm the changes, press the key (ENTER) to get out of the fields.

CONNECTIVITY

Through the optional serial port, the microprocessor control enables communication with the modern buildings BMS systems with the following protocols:

- MBUS/JBUS (RS485) serial card;
- MBUS/JBUS (RS232) for GSM modem serial card;
- LON Works serial card;
- BACnet per Ethernet – SNMP – TCP/IP serial card;
- BACnet per MS/TP serial card;

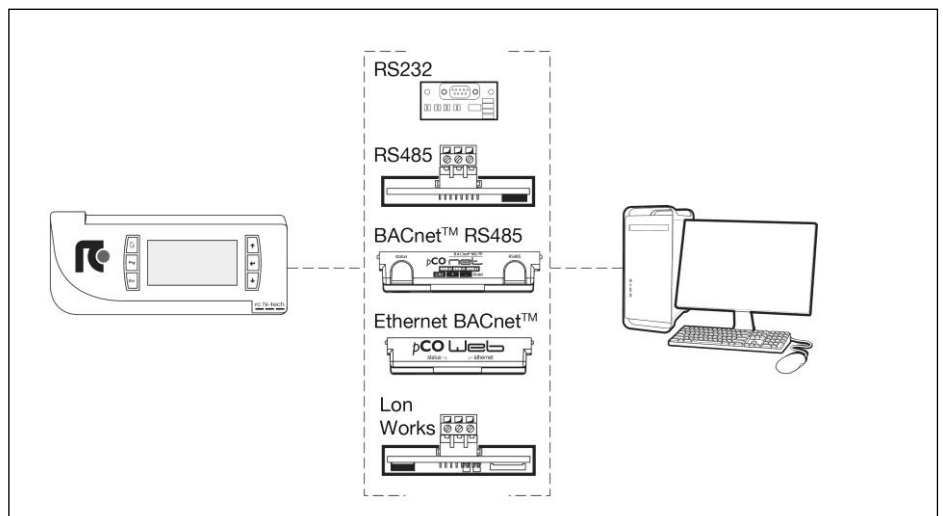

NEXT X TYPE

PASSWORD

- Level 1: On request of the End User. Allowing to reach USER menu
- Level 2: Asks to MEHITS Service: Allowing to reach SERVICE menu
- Level 3: Asks to MEHITS Service: Allowing to reach FACTORY menu

No passwords request to enter: UNIT, SETPOINT, IN/OUT, CLOCK, HISTORY menu

LAN NETWORK

The LAN is part of the control software and it is possible to connect up to 10 units.
 This type of connection allows to control the units in coherent way, moreover the units can be controlled and managed from a shared remote terminal.
 Electrical connections are on electrical panel connecting terminals.

LAN ADDRESS LIST

Unit #	1	2	3	4	5	6	7	8	9	10	Remote Terminal
Terminal address	1	2	3	4	5	6	7	8	9	10	32
Mother board address	11	12	13	14	15	16	17	18	19	20	-

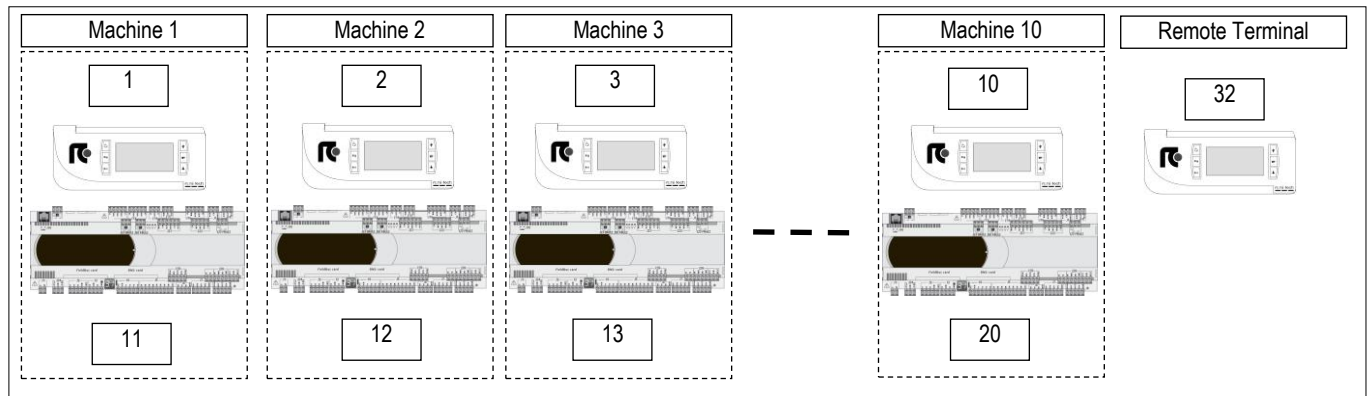

The unit connection to the local network (LAN) allows to perform the following functions:

- Balancing the operating hours among the different units by rotating the reserve units (Stand-by)
- Turning on the reserve units in case other units should turn off due to an alarm, maintenance or power feed interruption
- Turning on reserve units to offset the excessive thermal load
- Checking up to 10 units with a single user terminal (shared user terminal)

NEXT X TYPE - INSTALLATION DIAGRAMS

The machine must be installed with the fans section in the raised floor void.

Air flow direction:

- on unit front
- on unit back side

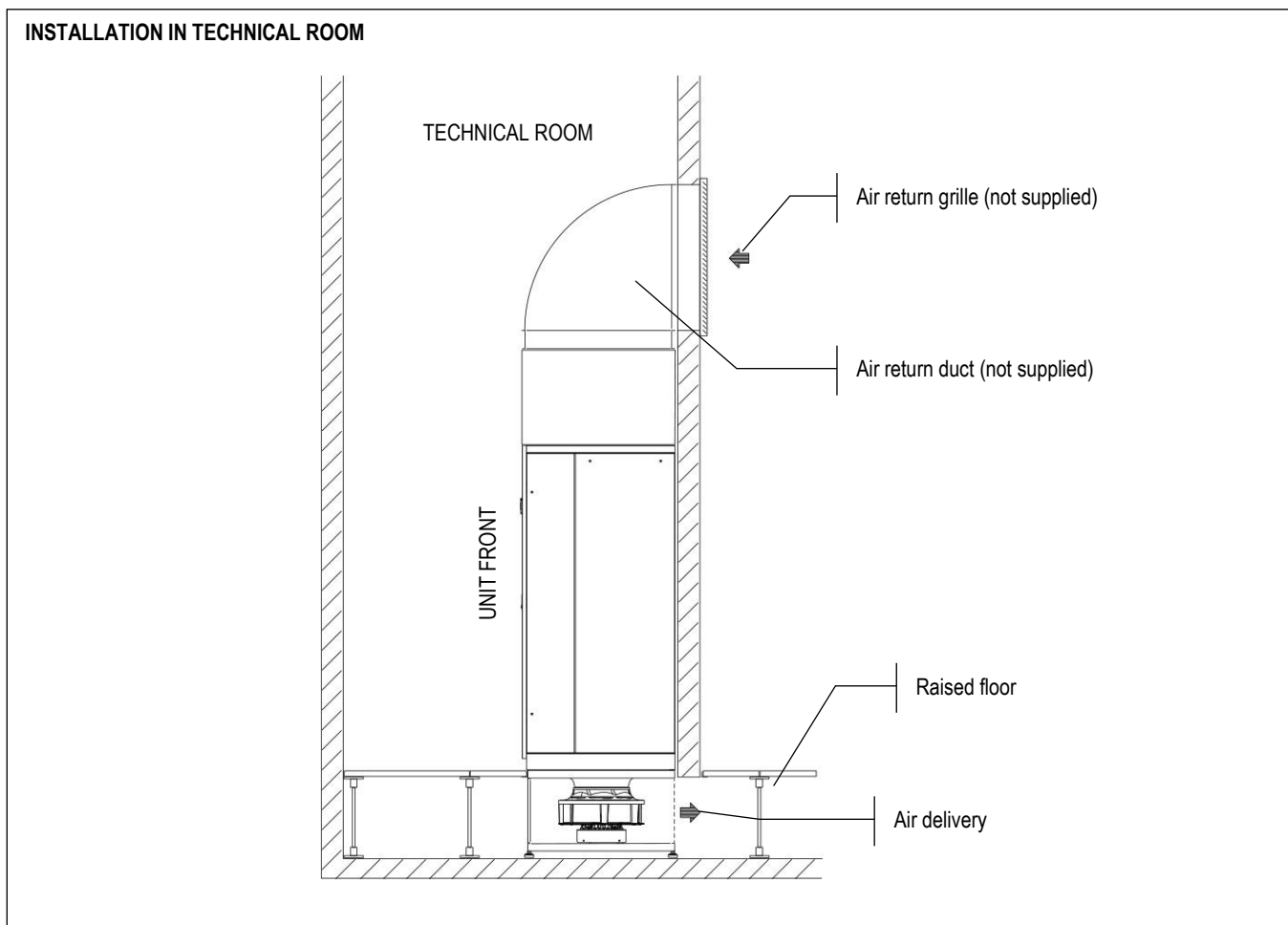
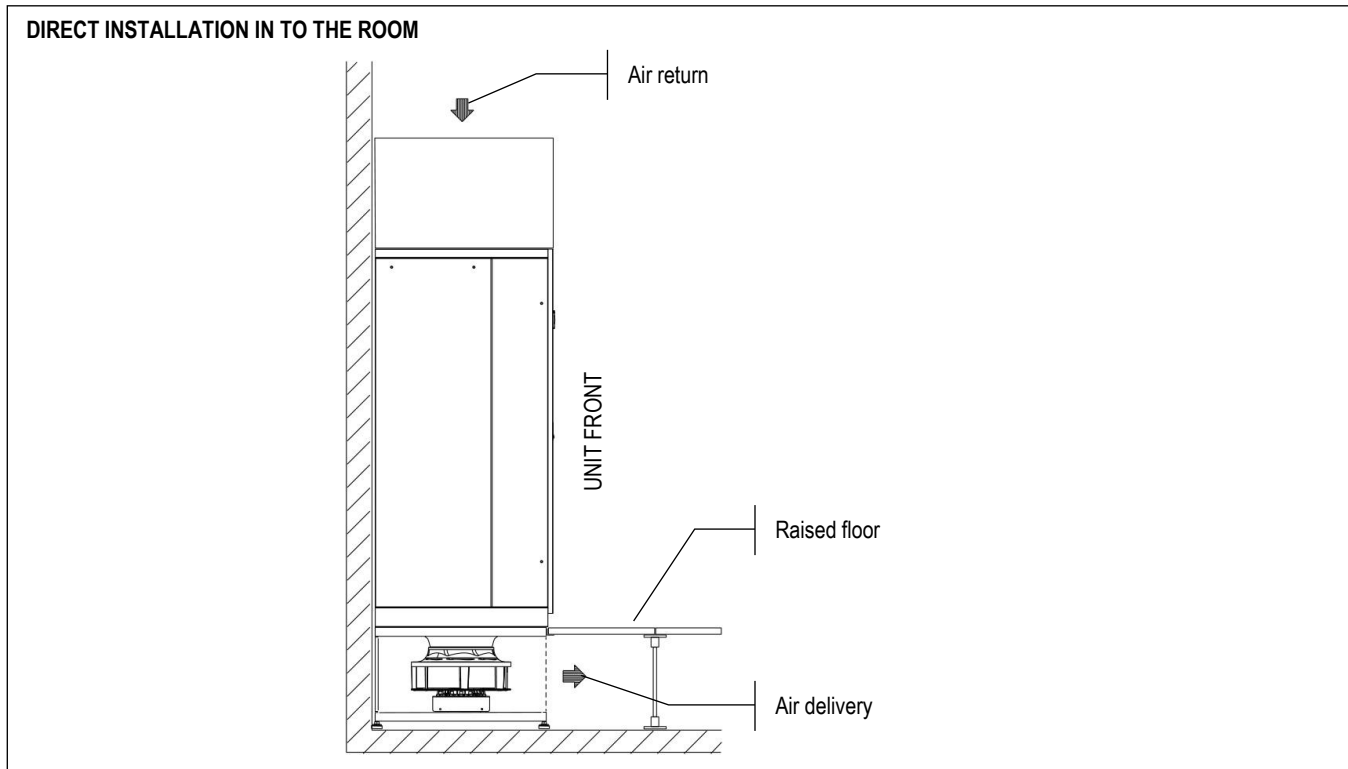

NEXT X TYPE

NEXT X TYPE – RAISED FLOOR HEIGHT

The machine must be installed with the fans section in the raised floor void.
The fans section is equipped with support holders with adjustable height. The minimum height is 525 mm while the maximum height is 620 mm as showed in the drawing.

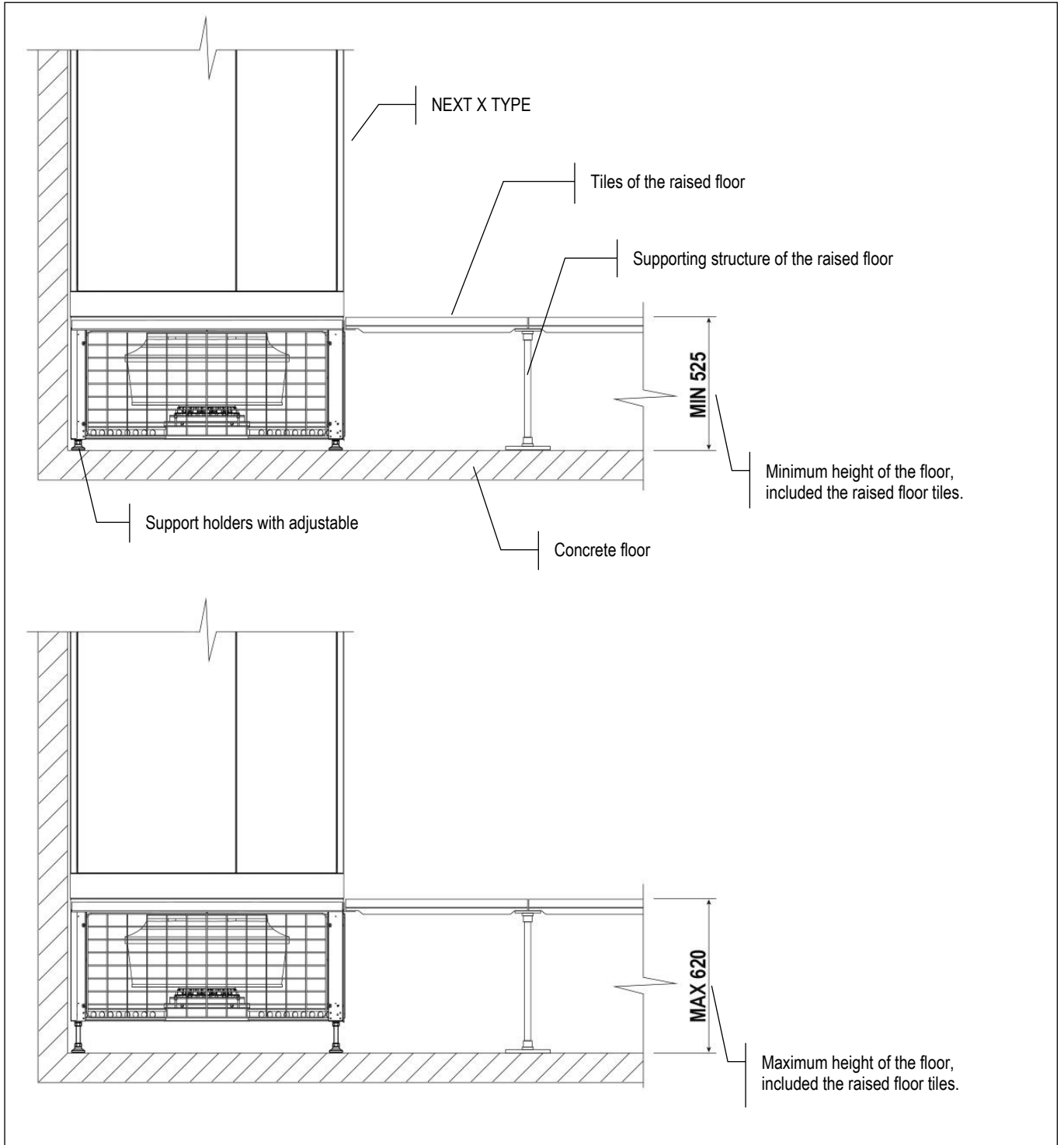

OPTIONAL ACCESSORIES – CHARACTERISED CONTROL VALVE WITH SENSOR-OPERATED FLOW CONTROL



These control valve combine in a single body the regulating valve, the balancing valve, the flow measurement and the shut-off valve. This simplifies the plant design, reduces the cost and time of installation of the unit and improves the efficiency of the system.

Distinctive features of these ball valves are the water flow rate equal percentage and optimal capacity control with a special characterization of the inserted disc. As is known, the variation of power expressed by the heat exchanger is not linear to the variation of the fluid flow. In fact, at a flow variation of 20% may correspond to a variation of power of 40%. The use of valves with characteristics equal percentage allows to solve this problem because the fluid flow rate does not vary linearly with the opening of the valve itself. The valve is also equipped with an ultrasonic system for measuring the flow. The measuring system gives to the controller the values of the instantaneous flow and allowing the microprocessor to precisely control the valve in order to provide the exact flow rate to the heat exchanger to satisfy the cooling capacity demand.

The measurement and the control on the water flow make the valve insensible to the plant operation pressure. High or low operating pressures of the system - so high or low water flow rates - are automatically compensated by the control system.

The characteristics described above allow this valve to replace the balancing valve. The system valve / microprocessor control, allow a permanent and automatic dynamic balancing of the system.

The valves have a leakage rate in class A - EN 12266-1, in practice they are tight and can also be used as shutoff valves.

The rotative actuator is controlled by a signal 0 ... 10VDC from the microprocessor controller. The actuator is equipped with an emergency button for manual operation and is maintenance-free.

The optional accessory is factory installed and don't modify the overall dimensions of the unit.

OPTIONAL ACCESSORIES – DOUBLE POWER SUPPLY WITH AUTOMATIC TRANSFER SWITCH



The motorised changeover switches automatically manage changeover under load between two three-phase power supplies, or manually for emergency operations.

These transfer switching (TSE) devices are suitable for low voltage systems with interruption of the supply to the load during transfer.

The model supplied in the automatic version checks the source and switches over automatically, based on configurable parameters.

OPEN TRANSITION TYPE TRANSFER SWITCH WITH A MINIMUM INTERRUPTION OF THE SUPPLY DURING TRANSFER.

To maintain the microprocessor powered and avoid its restarts is mandatory to foresee the installation of the “temporary microprocessor power supply” optional accessory. The system guarantees the microprocessor power supply for a few minutes, in case of supply voltage failure.

The automatic transfer switch is installed over the electrical panel as indicated in the picture.

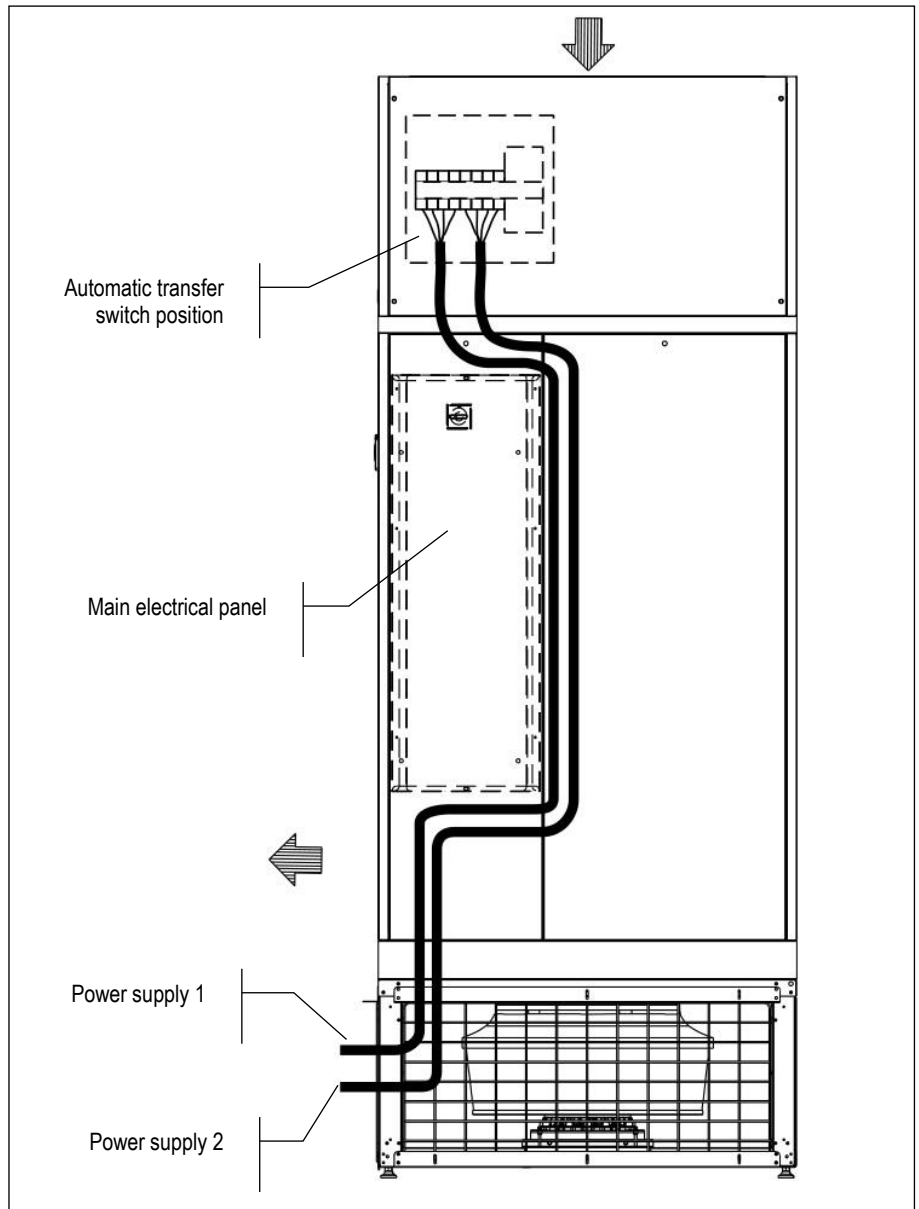

NEXT X TYPE

OPTIONAL ACCESSORIES - FLOOR STAND

The floor stand has the function of increasing the height of the fans section to match the raised floor.
The floor stand is equipped with support holders with adjustable height.
The machine must be installed with the fans section in the raised floor void.
The minimum height of the fans section including the floor stand is 620 mm while the maximum height is 850 mm as showed in the drawing.
The support frame is arranged to fix the fan sections of the machine.
The fans section is not equipped with support holders.

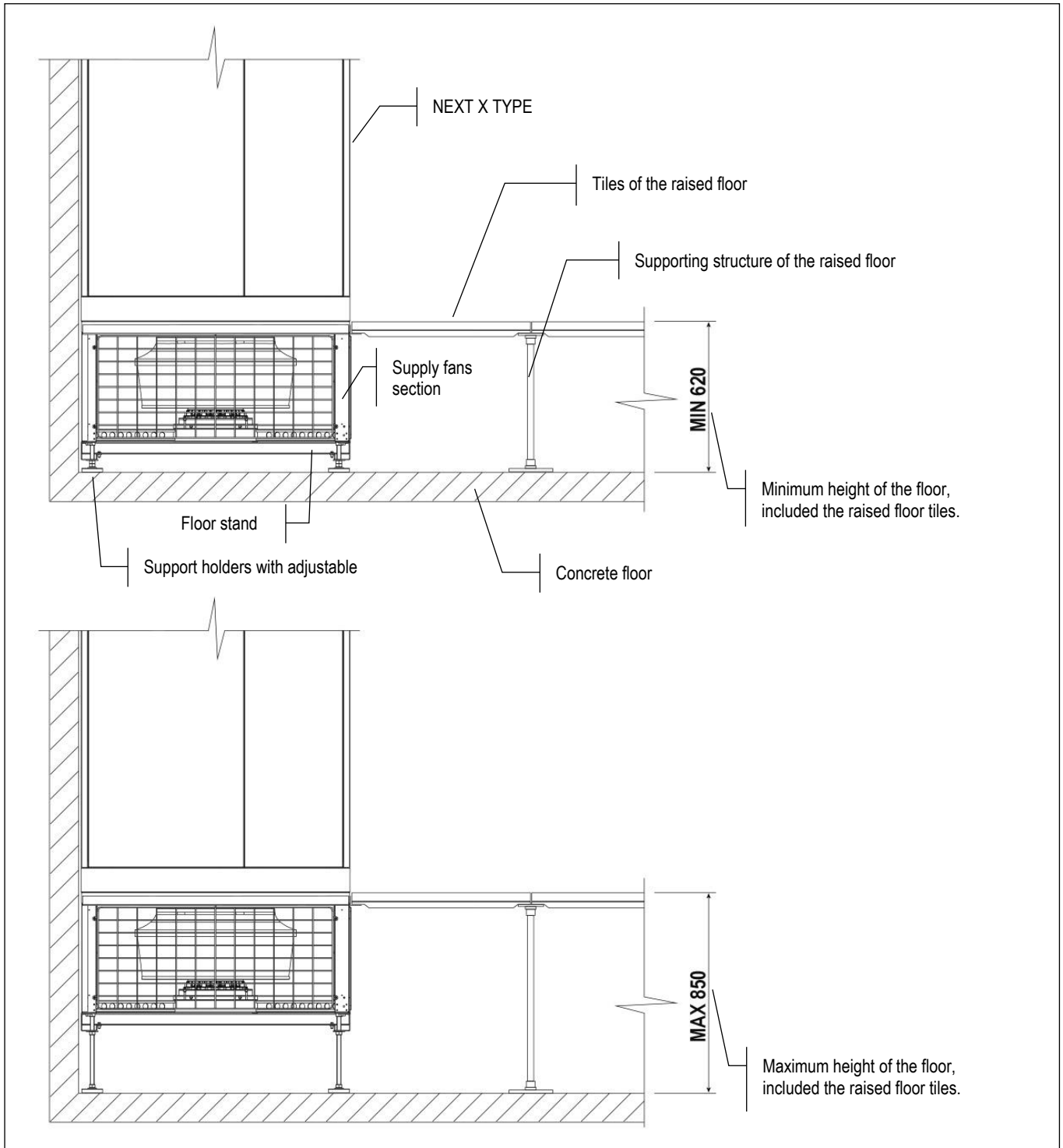

NEXT X TYPE

DIMENSIONS OF THE FLOOR STAND

SIDE VIEW



PLAN VIEW - SIZE T1

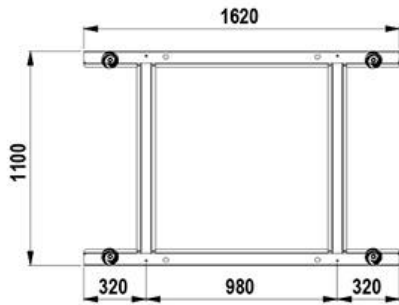

PLAN VIEW - SIZE T2

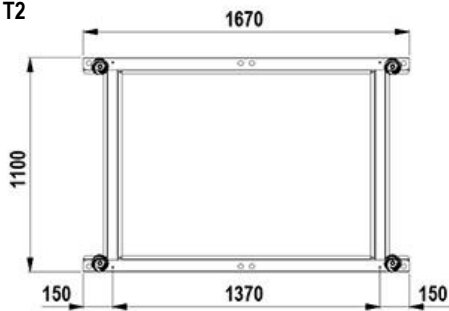

PLAN VIEW - SIZE T3

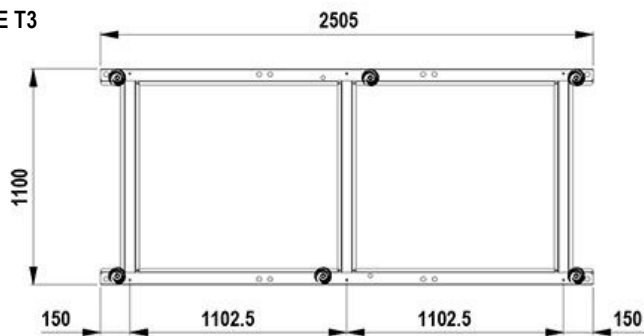

PLAN VIEW - SIZE T4

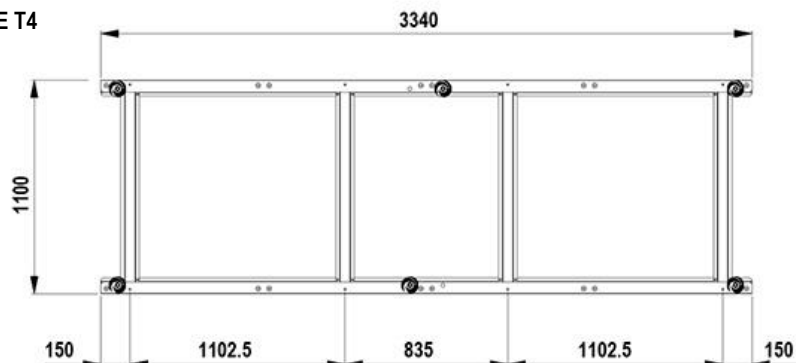

OPTIONAL ACCESSORIES - SANDWICH PANELS

The optional is designed to supply the panels only in Euroclass A1 of reaction to fire, furthermore allows a noise insulation of the panels of the air conditioners.

The pressure level reduction of the unit is about 2 dB(A). The reduction refers ONLY to the sound level radiated from the unit or in front of the unit. The noise level data on return and delivery air do not undergo reductions.

The accessory includes:

- External part as standard panel.
- Internal part in galvanized steel sheet.
- The inside noise insulation with special soundproof material.

REACTION TO FIRE CLASSIFICATION

On Italian territory, the classification is per the D.M. of June 26, 1984 and subsequent amendments, providing for a sort in "Classes" from 0 (non-combustible material) to 5 (extremely flammable material). In Europe, the classification is regulated per UNI EN 13501-1: 2009 ordered to "Euro-classes", from A1 (non-combustible material) to F (highly flammable material).

A comparison of the Italian and European classes is not possible because the methods and evaluation criteria are completely different. The comparison table below is being considered purely indicative.

Definition	Italian classes	Euro-classes
Non-combustible material	Class 0	A1
Combustible material, very limited contribution to fire	Class 1	A2 – B
Combustible material, limited contribution to fire	Class 2	A2 – B - C
Combustible material, medium contribution to fire	Class 3	C – D
Combustible material, highly contribution to fire	Class 4	E
Combustible material, easily flammable	Class 5	F

Is possible to provide the sandwich panels for the OVER units with air flow from the top.

This implies that the air intake must necessarily be from the base of the unit with front blind paneling.

The accessory increase the unit weight:

SIZE		T1 S	T2 S	T3 S	T4 S
Weight increasing (1)	kg	75	90	110	130

1. Add this value to the total unit weight

OPTIONAL ACCESSORIES – M5 EFFICIENCY AIR FILTERS

The M5 air filters replace the standard one.
The filters M5 generate a pressure drops higher than the standard ones.
The filters are made of polyester and are not regenerable.

MODEL		T1 S	T2 S	T3 S	T4 S
Additional pressure drops (1)	Pa	9	12	13	13

1. Additional pressure drops referred to nominal air flow and clean filter.

OPTIONAL ACCESSORIES – M6 EFFICIENCY AIR FILTERS

The M6 air filters replace the standard one.
The filters M6 generate a pressure drops higher than the standard ones.
The filters are made of synthetic microfiber and are not regenerable.

MODEL		T1 S	T2 S	T3 S	T4 S
Additional pressure drops (1)	Pa	39	52	57	60

1. Additional pressure drops referred to nominal air flow and clean filter.

OPTIONAL ACCESSORIES – F7 EFFICIENCY AIR FILTERS

The F7 air filters replace the standard one.
The filters F7 generate a pressure drops higher than the standard ones.
The filters are made of synthetic microfiber and are not regenerable.

MODEL		T1 S	T2 S	T3 S	T4 S
Additional pressure drops (1)	Pa	90	120	132	139

1. Additional pressure drops referred to nominal air flow and clean filter.

OPTIONAL ACCESSORIES – NON RETURN MOTORIZED DAMPER

The optional is installed inside the air handling section, after the filters section.

FRAMEWORK

- Opposed blade dampers in galvanized steel sheet.
- Actuator for damper control.

WORKING LOGIC

The damper opens at supply fans activation to allow air flow.

When the fans stop for failure or stop command, the damper closes, preventing air flow into the unit.

The actuator is equipped with spring return to ensure closure of the damper even in case of power failure.

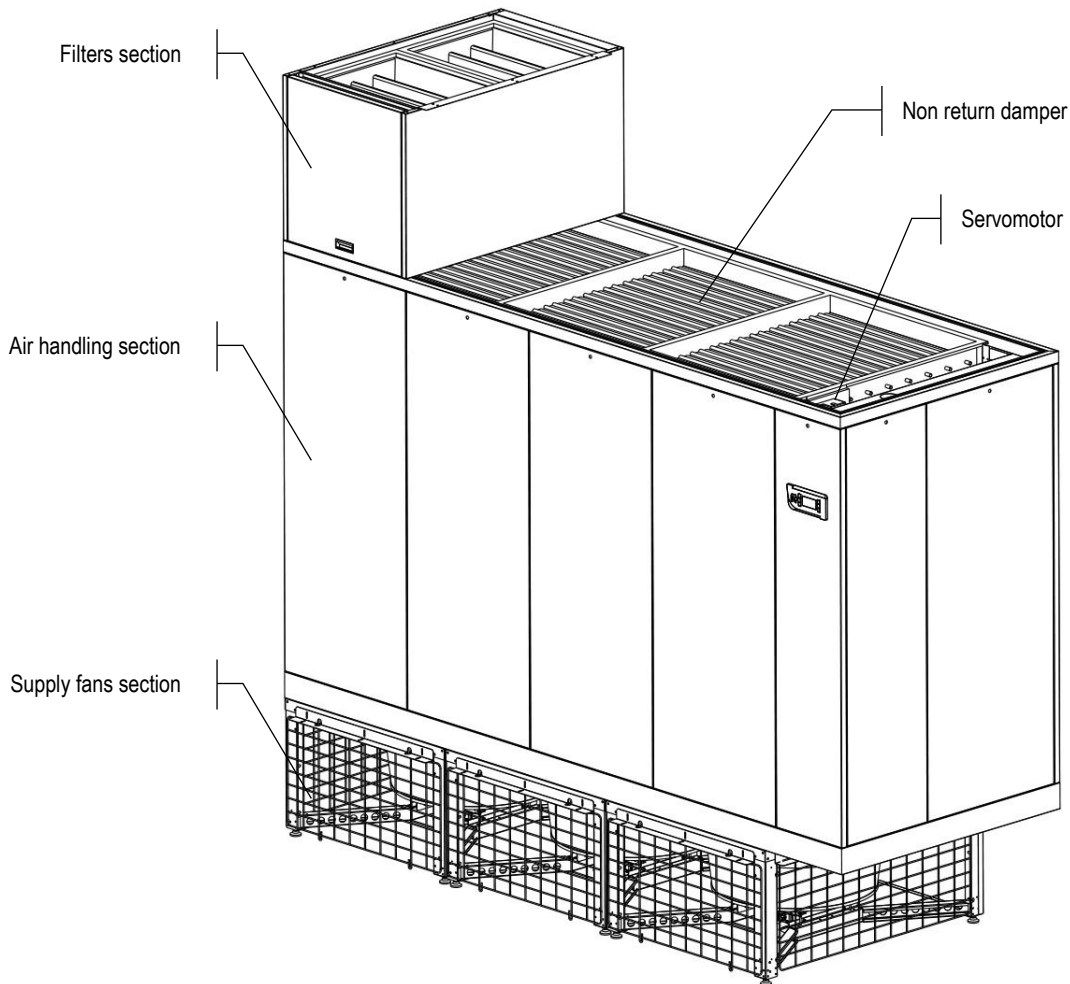

SIZE		T1 S	T2 S	T3 S	T4 S
Weight (1)	kg	22	30	45	55

1. Add this value to the total unit weight

OPTIONAL ACCESSORIES – COOLNET



COOLNET: Intelligent NET for IT Cooling that maximizes the energy saving in LOAD SHARING

MAIN FEATURES

COOLNET is a software that applies to chilled water air conditioners microprocessor control system. It optimizes the LOAD SHARING working mode and maximizes the energy savings.

OPTIONAL ACCESSORIES – ADAPTIVE SET-POINT



ADAPTIVE SET-POINT

An advanced algorithm that instantaneously detects the real thermal load of the indoor units and then conveys this information to the outdoor chillers, strongly increasing their operation.

- Dynamic variation of the chillers set point and water flow.
- Increasing of the free cooling mode.
- Adoption of the active redundancy system to better exploit stand-by chillers.

DATA CENTER MANAGER (Optional accessory)

DATA CENTER MANAGER is a centralized management system that ensures a smart communication between indoor chilled water units and the outdoor chillers.

The device manages the outdoor units according to the inlet and outlet temperature registered by the probes and by request of the indoor unit.

OPTIONAL ACCESSORIES – KIPlink – Keyboard in your Pocket



KIPlink - Keyboard In Your Pocket - is the innovative user interface based on WiFi technology that allows one to operate on the unit directly from the smartphone or tablet. Using KIPlink, it is possible to turn the unit on and off, adjust the set-point, plot the main operating variables, monitor in detail the status of the refrigerant circuits, the compressors, the fans and display and reset the possible alarms.

Scan the QR code on the electrical board of the unit to have access to the unit control through web browser web or App. The access is possible within the local WiFi network.

KIPlink hardware:

- Wi-Fi antenna in the electrical board;
- ON/OFF button with power LED and Unit status LED. Provided when the unit is equipped with KIPlink and without 6-keys keyboard (optional).

KIPlink allows;

- Easy and enhanced unit management
- Real-Time graphs and key trends
- Different information for each kind of user

OPTIONAL ACCESSORIES – RC CLOUD PLATFORM: WEB SERVICES BASED ON CLOUD TECHNOLOGY FOR REMOTE MONITORING AND MANAGEMENT OF AIR CONDITIONING PLANTS.



Log-in to the web site
<http://rccloudplatform.rcgroup.it>
automatic language recognition

RC Cloud Platform is an ecosystem of web services for remote monitoring and management of air conditioning plants; specifically designed for mobile usage on tablets and smartphones, it allows to access plant data everywhere on the go so saving time, money and delivering a higher service level to the customer.

TECHNOLOGY

Based on cloud technology it allows, through machines data telemetry, to monitor and control units on the field, process data and perform proactive maintenance.

The hardware heart of the system is the RC Cloud box that can collect plant data (up to 31 devices and up to 1000 registers).

Connectivity between monitored devices and RC Cloud box may be wired in Ethernet, RS485, RS232 and must be in MODBUS protocol.

RC Cloud Platform then send these data to dedicated server in cloud in through the mobile (GPRS or 3G) network or ADSL.

RC considers with great attention the security of customer information, so every communication channel may be encrypted in VPN, guaranteeing privacy and typical security policies commitment.

USER SIDE

RC Cloud Platform is designed for mobile communication. So the user just need a tablet or a smartphone to access the RC Cloud Platform and check his plant.

RC Cloud Platform App is available both on Android and iOS operating systems so the environment may be accessed directly from them beyond company site and platform site (<http://rccloudplatform.rcgroup.it>). Access through pc is available too.

FUNCTIONS

Telemetry & Data Export

Data polling and history of all data (1 year).
Export diagram and table (csv). **Your data always on the go.**

Multi Device

Many type of devices can be connected to the same box (chillers, close control, energy meters, flow meters, pumps,...).

Only a request: MODBUS protocol. Electrical connection in Ethernet, RS 485 or RS 232.

Multi Language

English native, RC Cloud Platform language pack is available for the main markets.

Virtual Display

Monitoring and control (on/off, alerts reset, main parameters change) as being beside the unit, in an augmented reality way.

Designed for Mobile.

Same as standing in front of the unit, when in your office or in any other place.

Internet Connectivity

ETHERNET + GPRS + 3G connection capability on Public and Virtual Private Network (VPN).
Your security and privacy are a top priority.

Alerts Warning through:

- Push notification
- e-mail
- Voice calls
- SMS

Processing of specialized plant KPI to get:

- Energy performance (gross instant EER)
- Components Failure Forecast (coming soon)
- Unit diagnosis

MACHINE DRAWINGS

NEXT X TYPE T1 S – Dimensions mm

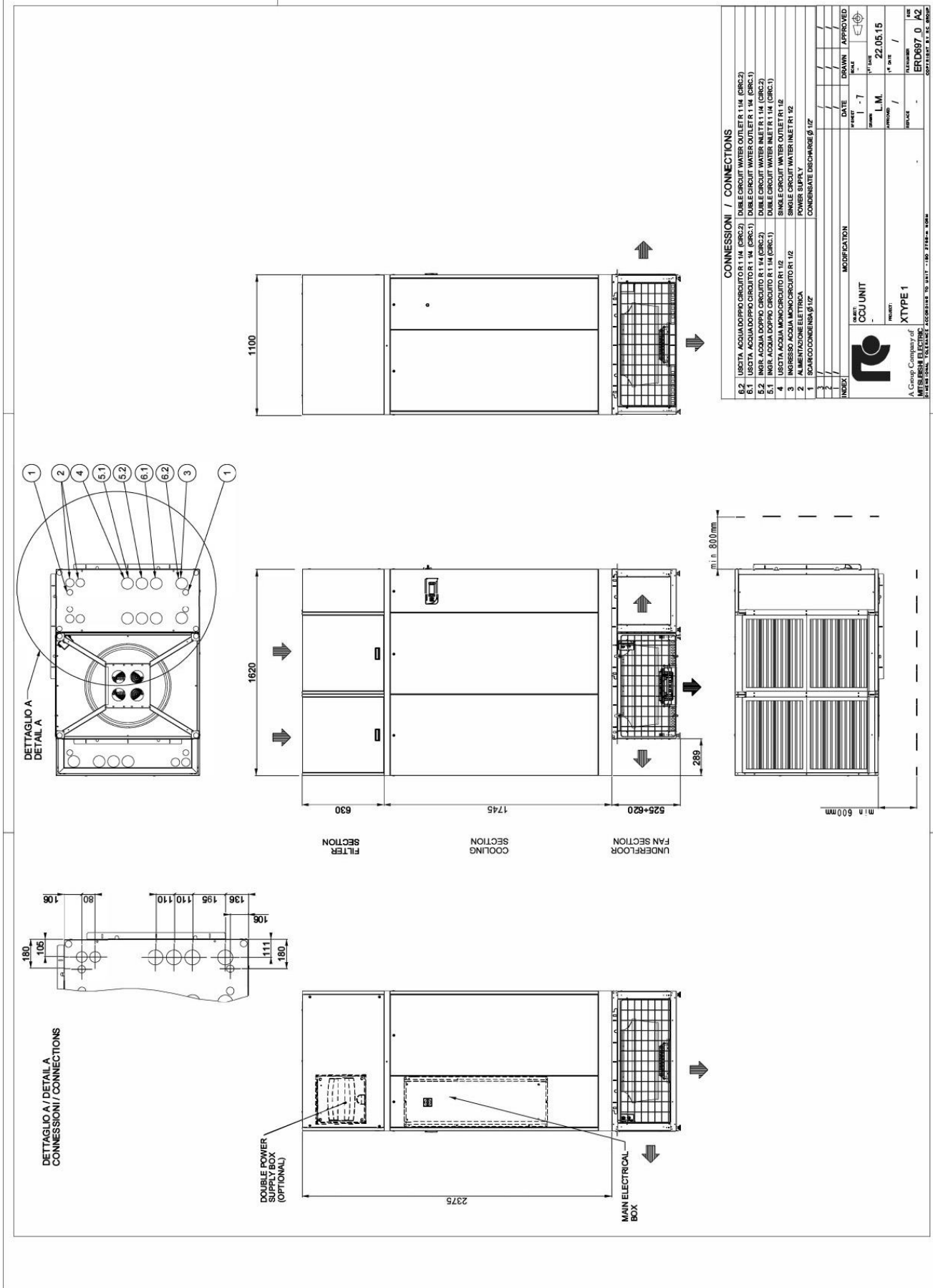

NEXT X TYPE

MACHINE DRAWING – NEXT X TYPE T2 S – Dimensions mm

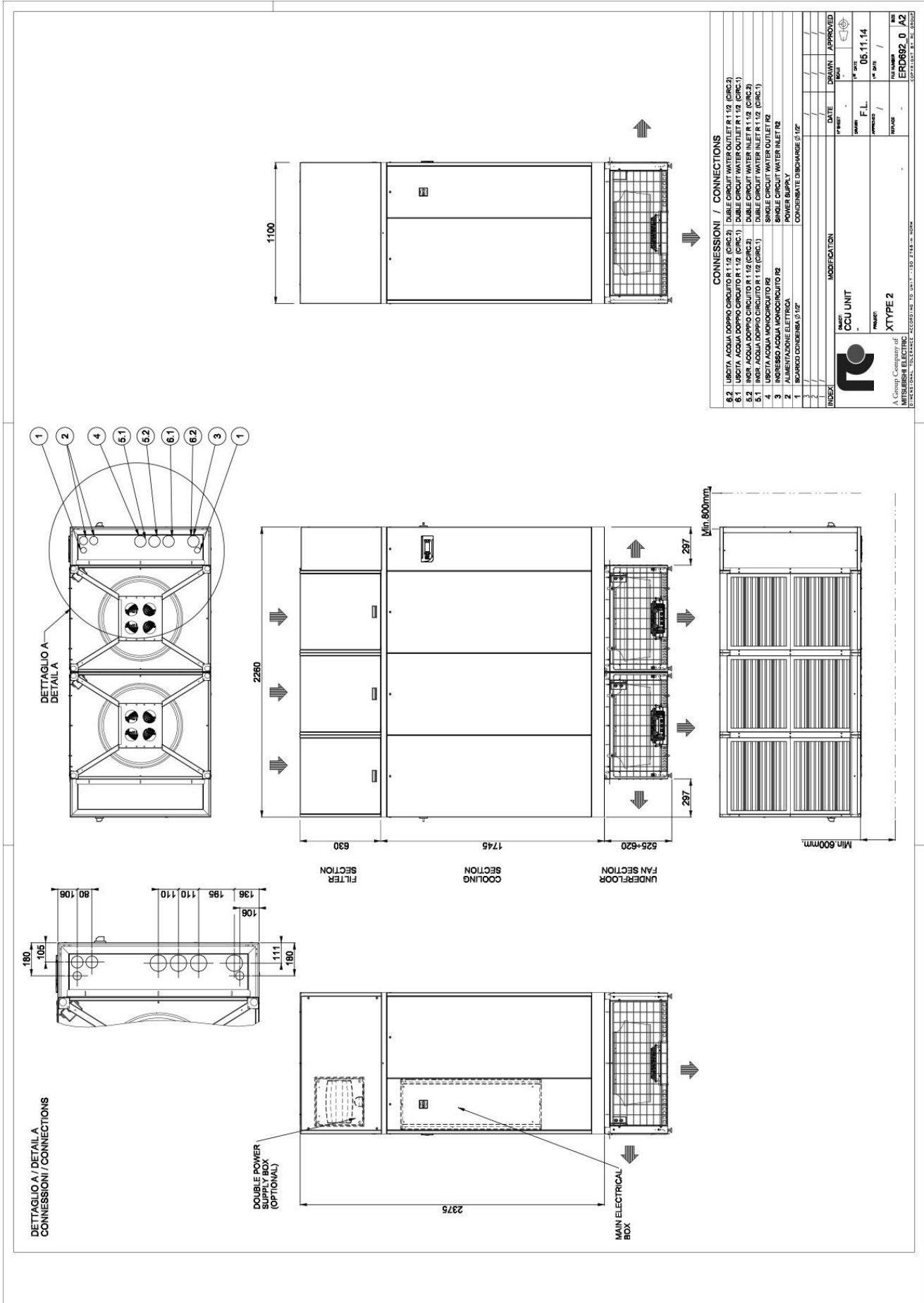

NEXT X TYPE

MACHINE DRAWING – NEXT X TYPE T3 S – Dimensions mm

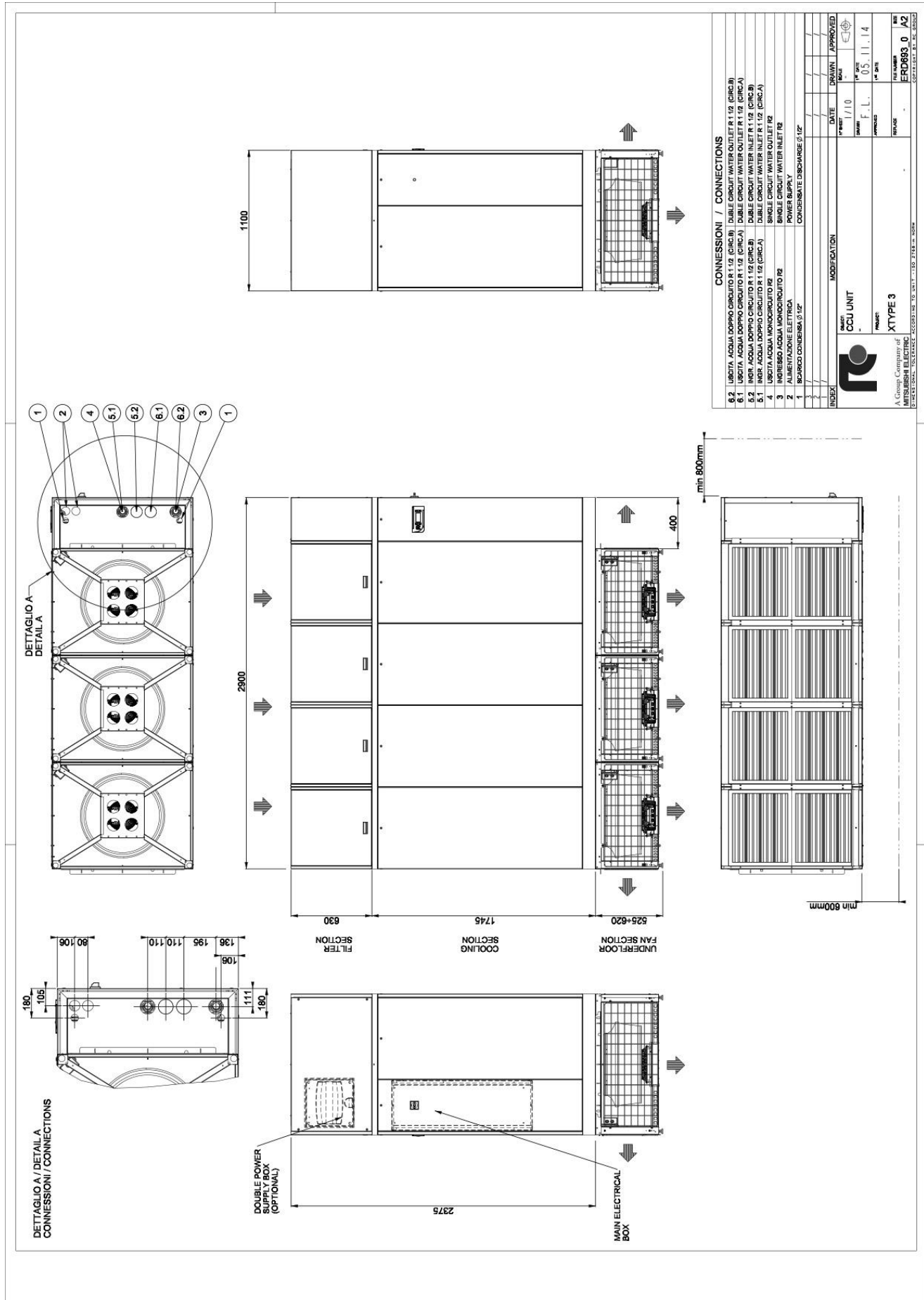

NEXT X TYPE

MACHINE DRAWING – NEXT X TYPE T4 S – Dimensions mm

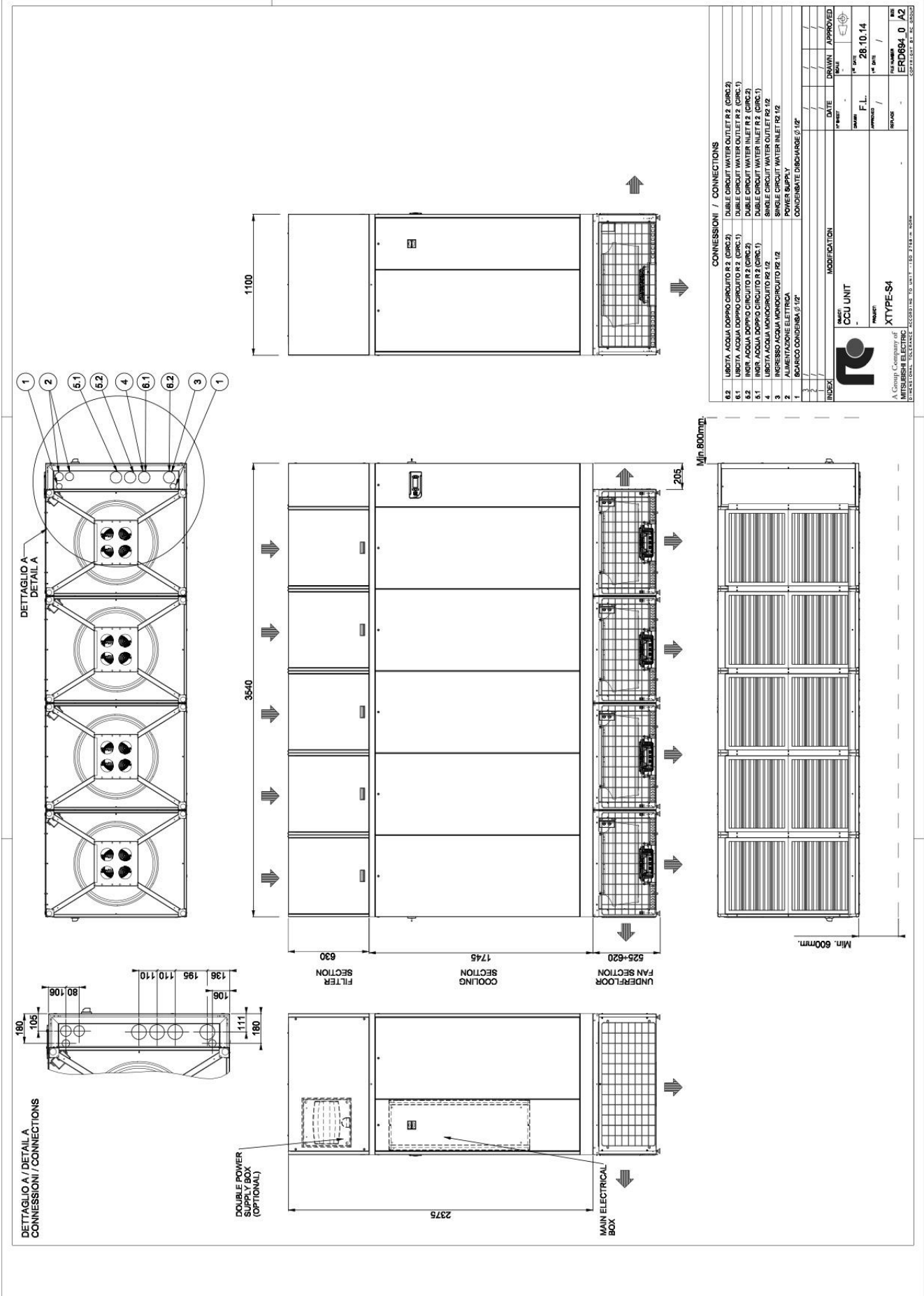



for a greener tomorrow

Eco Changes is the Mitsubishi Electric Group's environmental statement, and expresses the Group's stance on environmental management. Through a wide range of businesses, we are helping contribute to the realization of a sustainable society.



MITSUBISHI ELECTRIC HYDRONICS & IT COOLING SYSTEMS S.p.A.

Via Roma 5 • 27010 Valle Salimbene (PV) • Italy
Ph. +39 0382 433811 • Fax +39 0382 587148

www.rcitcooling.com
www.melcohit.com